



FRC 1640 Arm Analysis

Scoring arm for Logomotion

Clem McKown

12-January-2011

Situations Examined

- ◆ Autonomous
- ◆ Floor pick-up – front
- ◆ Floor pick-up – rear
- ◆ Loading Station – front
- ◆ Loading Station - rear

Analysis updated for change in
The Robot RevA from deployed
limit of 60 in vertical right
cylinder to 84 in.

Autonomous

- 1) Robot starts in starting envelope with Ubertube loaded

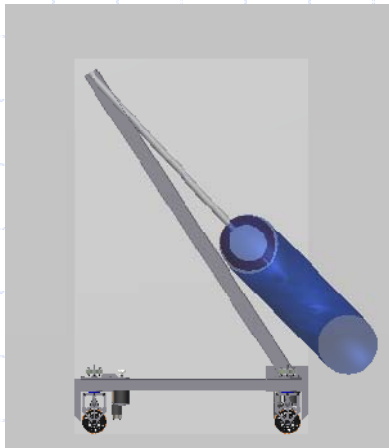

Note: Arm sequence is important to avoid breaking the 60 in cylinder. This will need to be a software task.

Sequence not important for 84 in cylinder

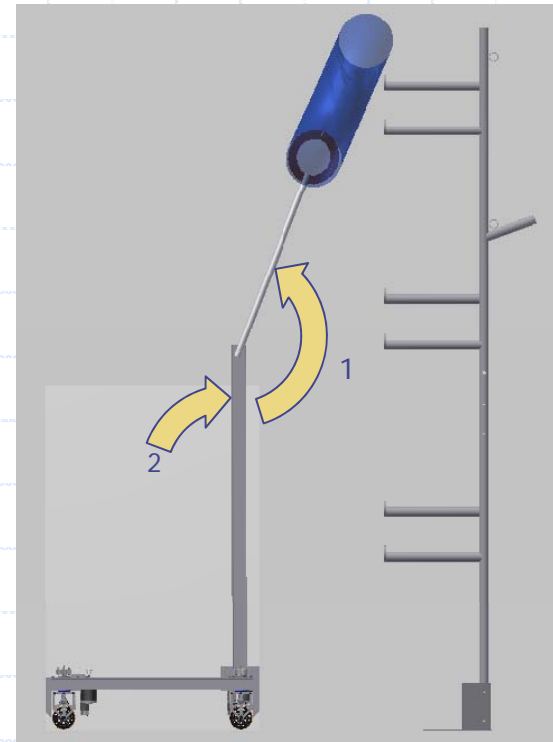

- 2) Elbow & Shoulder deploy to achieve scoring height. Ubertube is naturally at a good orientation for scoring

Floor pick-up - front

Floor pick-up forwards breaks the 60 in
(and 84 in) cylinder. We can't do this.

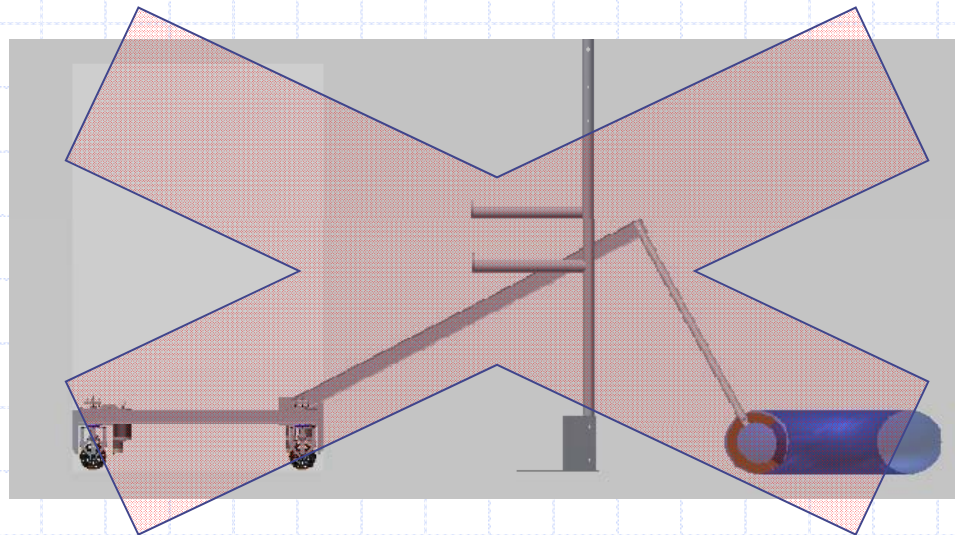

Floor pick-up - rear

1) Floor pick-up is possible from the robot rear

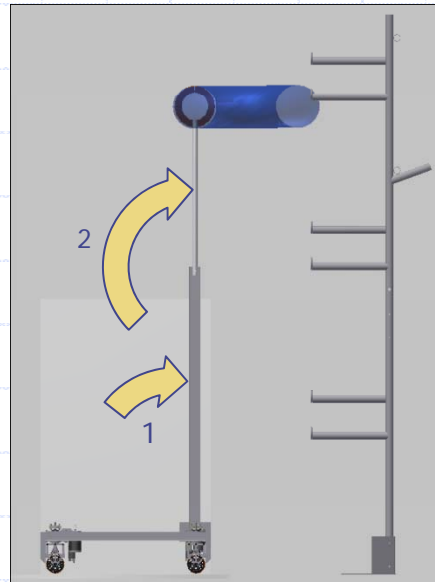
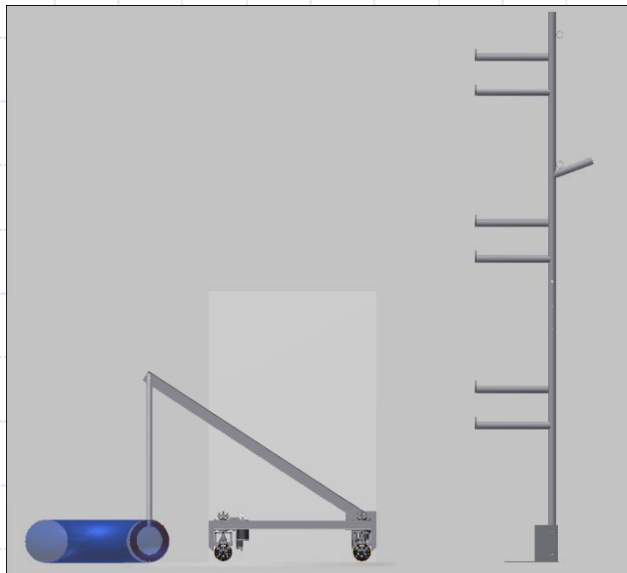

3) Logo Piece needs to be rotated to score

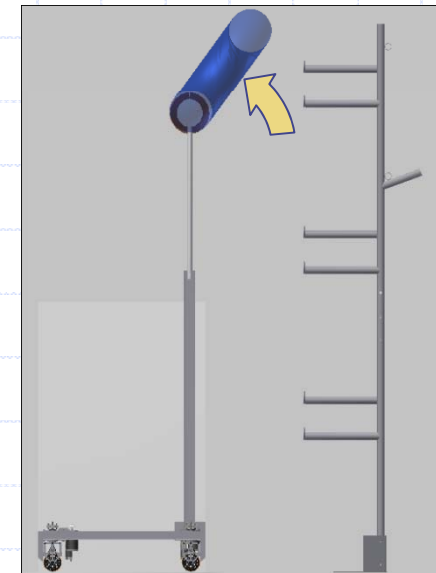

2) Rotating the arm to score high leaves the Logo Piece leading edge too low

Loading Station - front

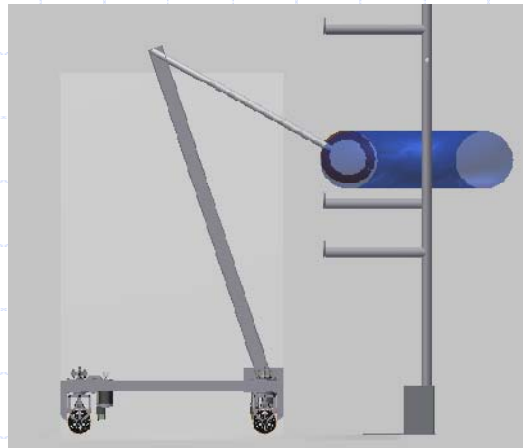

1) Front Loading
no problem

Sequence not
important for
84 in cylinder

2) Shoulder needs to
go retrograde before
elbow straightens.
Logo Piece at bad
scoring angle

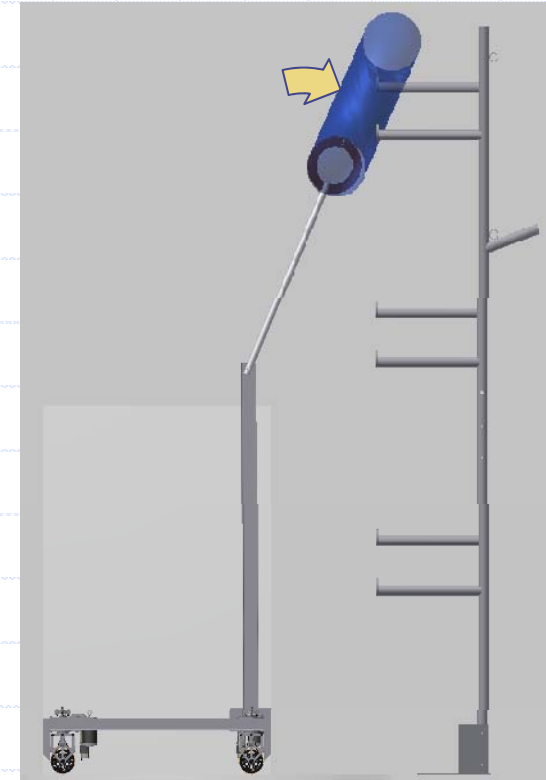
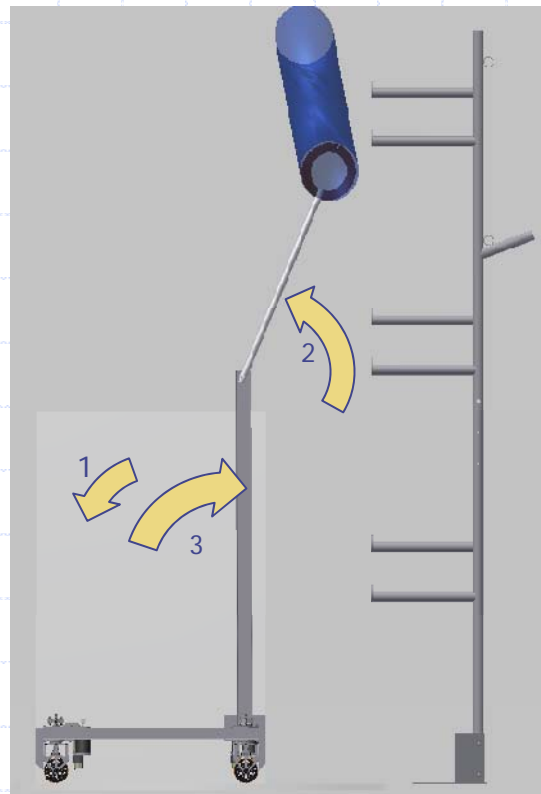

3) Logo Piece
needs to be
rotated to score

Loading Station - rear

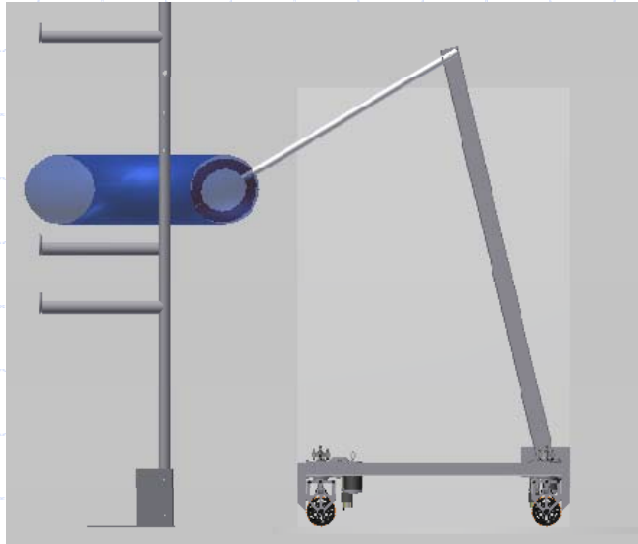

1) Rear Loading okay; avoids need to turn around

Sequence not important for 84 in cylinder

2) No retrograde motion. Shoulder moves first, then elbow. Logo Piece in scoring position.

