

2

1

B

B

0.5 x 0.5 x 0.125 square tube
(1) req'd per robot

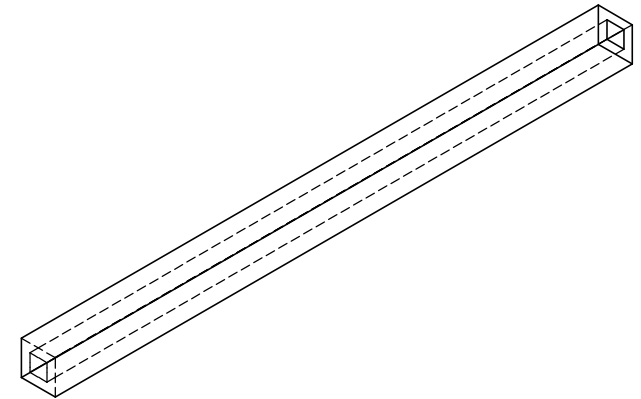
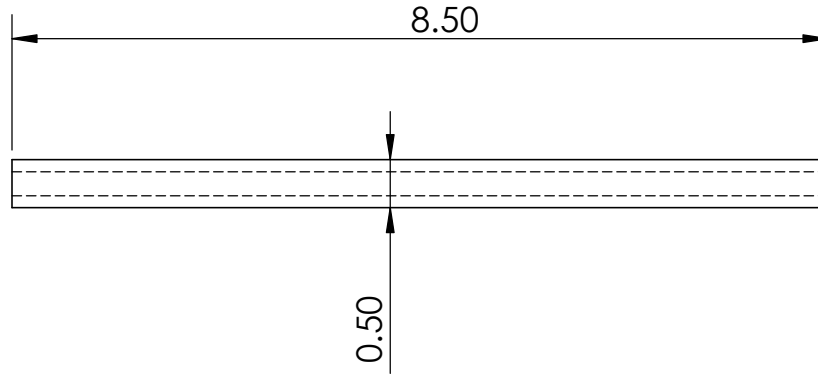

A

A

		UNLESS OTHERWISE SPECIFIED:		NAME	DATE			
		DIMENSIONS ARE IN INCHES	DRAWN			TITLE:		
		TOLERANCES:	CHECKED					
		FRACTIONAL ±	ENG APPR.					
		ANGULAR: MACH ± BEND ±	MFG APPR.					
		TWO PLACE DECIMAL ±	Q.A.			SIZE	DWG. NO.	REV
		THREE PLACE DECIMAL ±	COMMENTS:			A	catend	
		INTERPRET GEOMETRIC TOLERANCING PER:				SCALE: 1:2	WEIGHT:	SHEET 1 OF 1
		MATERIAL						
		FINISH						
	NEXT ASSY	USED ON						

PROPRIETARY AND CONFIDENTIAL
 THE INFORMATION CONTAINED IN THIS DRAWING IS THE SOLE PROPERTY OF <INSERT COMPANY NAME HERE>. ANY REPRODUCTION IN PART OR AS A WHOLE WITHOUT THE WRITTEN PERMISSION OF

2

1