

Port	Design Function	IC Pin	Connector	Connector Pin
	VDDIO		J2	1
P0[0]	General expansion connector (J2) Pin 2	71	J2	2
P0[2]	General expansion connector (J2) Pin 3	73	J2	3
P0[4]	General expansion connector (J2) Pin 4	76	J2	4
P0[6]	General expansion connector (J2) Pin 5	78	J2	5
P4[4]	General expansion connector (J2) Pin 6	82	J2	6
P4[6]	General expansion connector (J2) Pin 7	84	J2	7
P6[0]	General expansion connector (J2) Pin 8	89	J2	8
P6[2]	General expansion connector (J2) Pin 9	91	J2	9
P6[4]	General expansion connector (J2) Pin 10	6	J2	10
P6[6]	General expansion connector (J2) Pin 11	8	J2	11
P12[2]	General expansion connector (J2) Pin 12	67	J2	12
P2[6]	General expansion connector (J2) Pin 13	2	J2	13
	GND		J2	14
	VDDIO		J3	1
P0[1]	General expansion connector (J3) Pin 2	72	J3	2
P0[3]	General expansion connector (J3) Pin 3	74	J3	3
P0[5]	General expansion connector (J3) Pin 4	77	J3	4
P0[7]	General expansion connector (J3) Pin 5	79	J3	5
P4[5]	General expansion connector (J3) Pin 6	83	J3	6
P4[7]	General expansion connector (J3) Pin 7	85	J3	7
P6[1]	General expansion connector (J3) Pin 8	90	J3	8
P6[3]	General expansion connector (J3) Pin 9	92	J3	9
P6[5]	General expansion connector (J3) Pin 10	7	J3	10
P6[7]	General expansion connector (J3) Pin 11	9	J3	11
P12[3]	General expansion connector (J3) Pin 12	68	J3	12
P2[7]	General expansion connector (J3) Pin 13	3	J3	13
	GND		J3	14

The information contained in this document is excerpted from:

CY8CKIT-003
PSoC® 3 FirstTouch™ Starter Kit Guide
Spec. # 001-49613 Rev. *B

Cypress Semiconductor
 198 Champion Court
 San Jose, CA 95134-1709
 Phone (USA): 800.858.1810
 Phone (Intl): 408.943.2600
<http://www.cypress.com>

© Cypress Semiconductor Corporation, 2009.

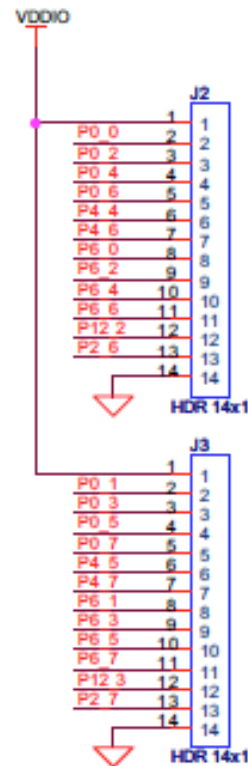

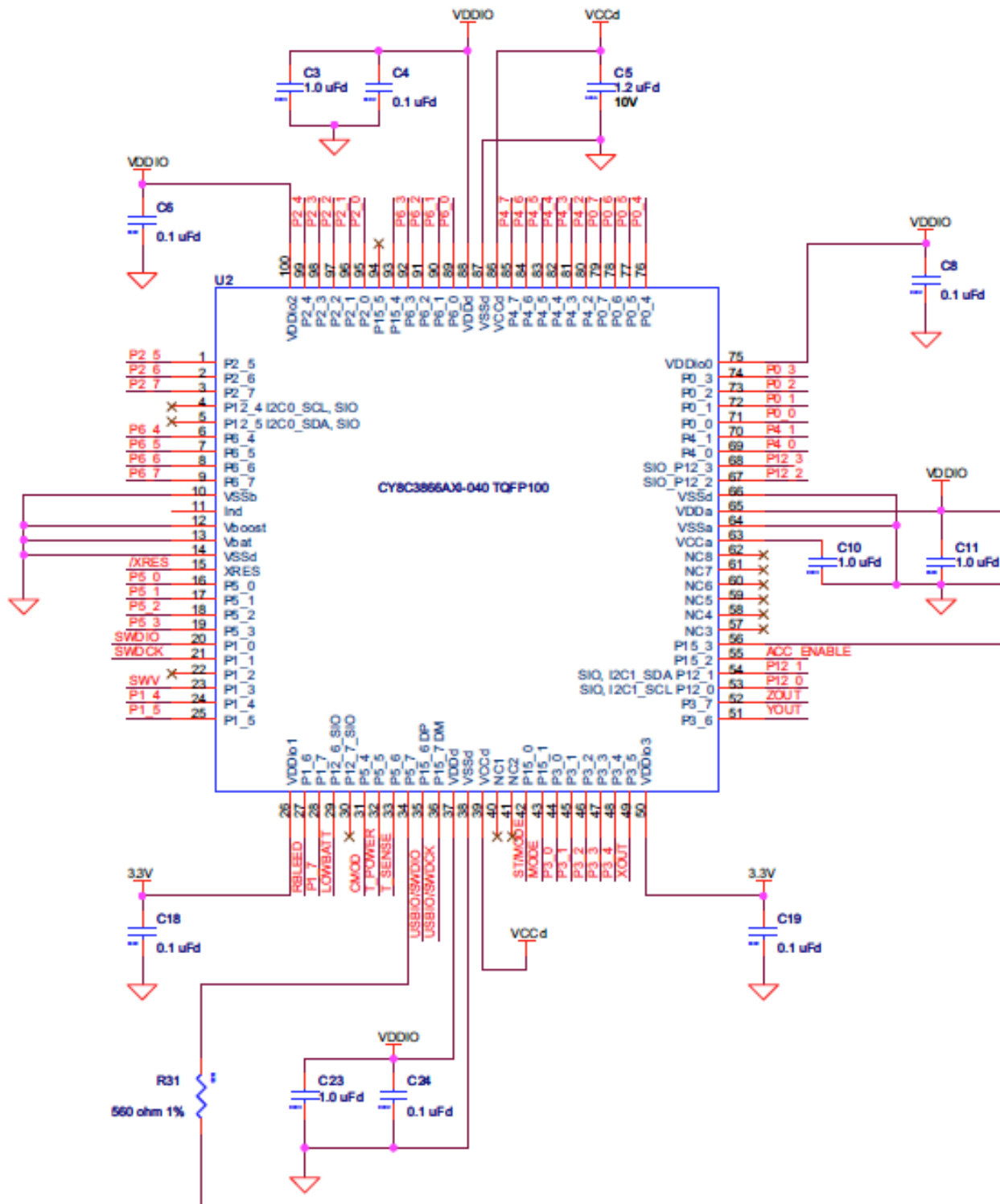

© Cypress Semiconductor Corporation, 2009.